

**Let your message speak for itself with the Eye-Point®!**

Eye-Point® is one of the latest product groups in an already extensive Audipack range. It's the ideal solution for a professional and elegant infotainment system.

**The product**

The Eye-Point has a new age design and is a very flexible mobile presentation display that clearly communicates your message or information to your target group.

The modern look and distinguished design are easy to implement in any environment – from showroom to supermarket.

*It's a real 'Eye-catcher' for all applications.*



Bold



Glass



Bold

The flat panel is hidden and protected by the neatly assembled and strong casing. This product serves the demanding needs of you and your customers. By using a digital signage software, this concept achieves a maximum result on an interactive level.

Eye-Point is currently available for flat panel displays from 40" to 65", for both portrait and landscape orientation. Thanks to the extensive choice of materials, colours and wrappings, the Eye-Point is applicable in any environment and situation.

Eye-Point can be supplied in a standard metal version as well as in a very trendy design glass version.

All models feature a standard integrated quick-installation L&S5 swivelling arm for the flat panel, which also reveals plenty of space for installing PC's and other equipment.

The flat panel display will be mounted with the famous Audipack L&S5 mounting system; the universal AV mounting system that allows you to install or swap any brand and type of flat panel without using tools!



**The options...**

**Eye-Point Bold**

The Eye-Point "Bold" is a flexible and modern shaped information display with an open active area in the front bezel. This model is perfect for a random range of (touch screen) displays. The open front bezel gives direct access to the screens surface for the viewer or operator.



**Eye-Point Glass**

An even more distinguished version of the Eye-Point is the "Glass" version. A glossy, design front fabricated of tempered glass accentuates your message to a higher level. Personalize the Eye-Point by choosing company colours or stickers.



The glass panel covers the full front of the Eye-Point and protects also the active area of the flat panel. The Glass version is also available as an outdoor version.

**Benefits:**

- ▲ Your application
- ▲ Your choice of flat panel
- ▲ Your choice of pc or media player
- ▲ Your choice of software
- ▲ Your colour or finish design
- ▲ You are in control!



**Eye-Point outdoor**

The Eye-Point outdoor is the perfect tool for your outdoor signage applications. Invite your customers or point the way. The flexible Eye-Point makes it easy to implement in any environment; even colour choice and sticker wrappings are standard applicable on the display. The all weather proof display safely conceals your equipment and keeps it protected. Integrated cooling, ventilation and heating facilities allow any weather environment for the Eye-Point.

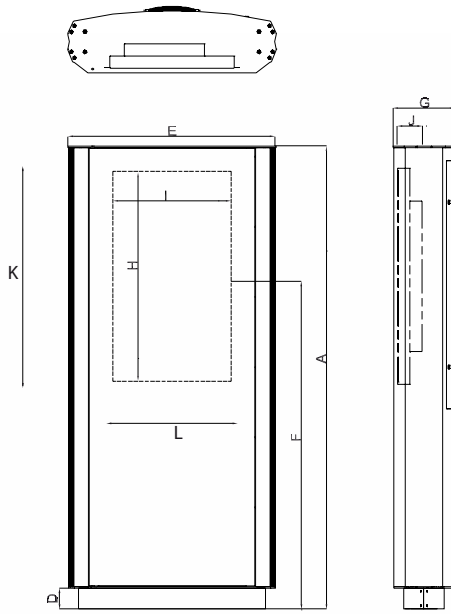

Glass	P5069
	<b>46"</b>
	Portrait
A	2242
B	-
C	-
D	101
E	996
F	1612
G	299
H	1020
I	575
J	150
<b>K</b>	<b>1120</b>
<b>L</b>	<b>700</b>

Challenge us with your applications!

Separate brochures are available for:



It's great to have solutions  
www.audipack.com

**Uniflatfix PRO flat panel brackets L&S 3 + L&S 5**

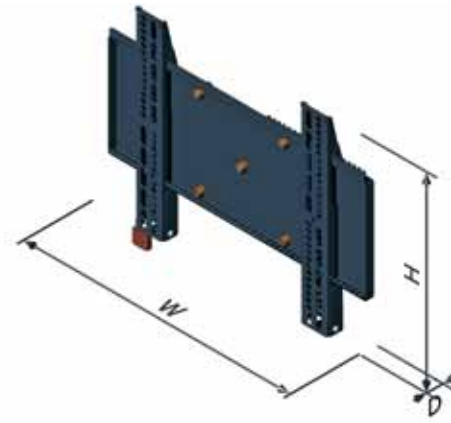

Ref.	392691	392692	392693
Dimensions in mm	W 516 x D 34 x H 382	W 716 x D 34 x H 502	W 860 x D 34 x H 502
Max. range mounting points in mm	W 470 x H 360	W 670 x H 446	W 810 x H 446
Max. load	50 kg	50 kg	50 kg
Colour	Black RAL 9005	Black RAL 9005	Black RAL 9005



Protection cover

Transport Trolley



Flightcase

**Eye-Point indoor**

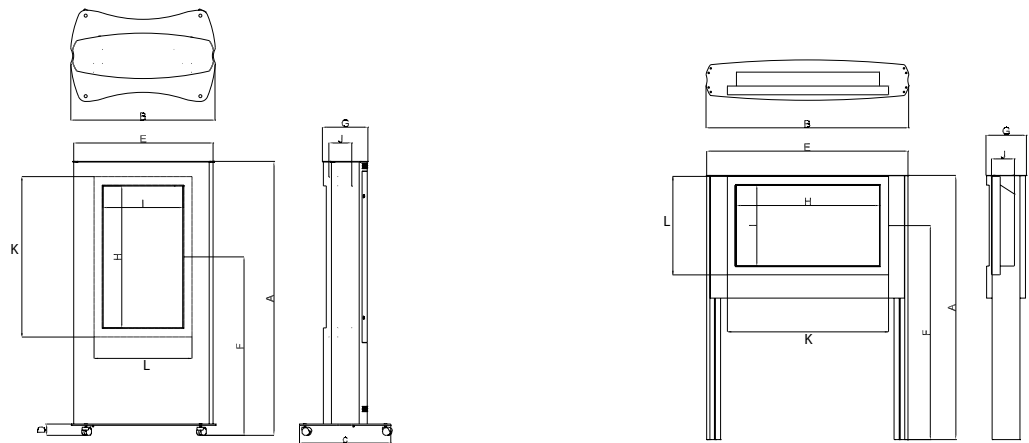

Glass	P3960	P3899	P3961	P3962	P3963	P3964	P3965	P3966	P3967	P3968
<b>Bold</b>	P3734	P3901	P3891	P3902	P3892	P3903	P3893	P3904	P3894	P3896
	<b>40"</b>	<b>42"</b>	<b>46"</b>	<b>47"</b>	<b>50"</b>	<b>52"</b>	<b>55"</b>	<b>57"</b>	<b>65"</b>	<b>42"</b>
	Portrait	Portrait	Portrait	Portrait	Portrait	Portrait	Portrait	Portrait	Portrait	Landscape
A	1800	1800	1885	1885	1985	1985	2080	2080	2230	1728
B	950	950	1010	1010	1075	1075	1135	1135	1235	1326
C	600	600	650	650	650	650	700	700	750	-
D	75	75	75	75	75	75	75	75	75	-
E	915	915	975	975	1040	1040	1100	1100	1200	1316
F	1177	1177	1217	1217	1251	1251	1291	1291	1352	1390
G	299	299	299	299	299	299	299	299	299	299
H	893	930	1019	1037	1114	1152	1225	1262	1439	930
I	486	523	573	592	611	648	673	710	810	523
J	150	150	150	150	150	150	150	150	150	150
<b>K</b>	<b>1013</b>	<b>1050</b>	<b>1139</b>	<b>1157</b>	<b>1234</b>	<b>1272</b>	<b>1345</b>	<b>1382</b>	<b>1559</b>	<b>1050</b>
<b>L</b>	<b>606</b>	<b>643</b>	<b>693</b>	<b>712</b>	<b>731</b>	<b>768</b>	<b>793</b>	<b>830</b>	<b>930</b>	<b>643</b>

AP/EP/EN/V2.0/2009



Industriestraat 2  
NL-2751 GT Moerkapelle  
The Netherlands  
Tel. +31795931671  
Fax +31795933115  
audipack@audipack.com  
www.audipack.com

Your Audipack® dealer:  
[www.monitorhalterung.de](http://www.monitorhalterung.de)

